

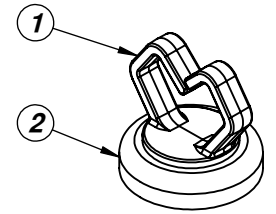

62401

ITEM NO.	PART NUMBER	DESCRIPTION	MATERIAL	FINISH	QTY.
1	62429	1/2" CABLE HOLDER, WHITE	POM-WHITE (NATURAL) POLYOXYMETHYLENE		1
2	82007W	10LB., N35M Ø.75" (19mm) O.D. MAGNET MOUNT Ø.256" (6.5mm) HOLE, WHITE	CUP-CRS DC01 MAGNET-NdFeB 35M	CUP-WHITE EPOXY MAGNET-NiCuNi	1

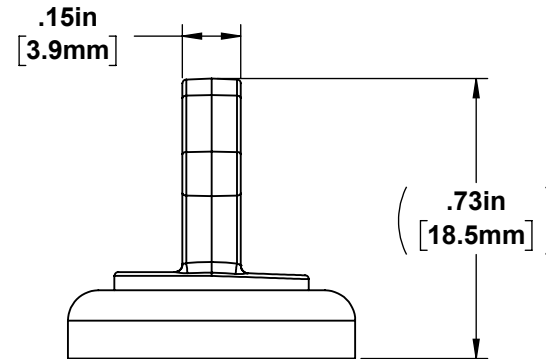

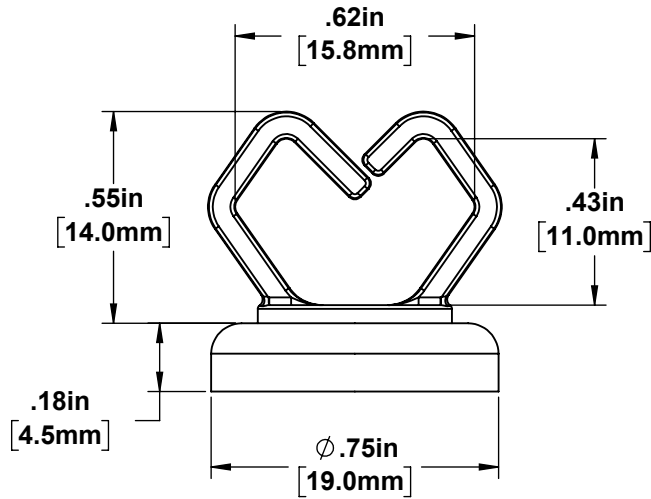

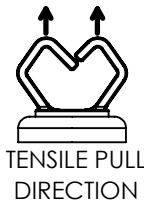
 <b>UL LISTING</b> <b>Magnetic Cable Holder 1/2"</b>		
ANSI/UL 1565	Positioning Devices TYPE 21 E359769	Mechanical Tensile Strength: 10 LBS. (45N) No Load Rating
CAN	CSA-C22.2 No. 18.5	
ALL TESTING PERFORMED USING 3mm THICK 1008-1010 STEEL PLATE		



**PLENUM RATED**  
Suitable in air handling systems

**Please read before use!** Disclaimer: Mag Daddy neither assumes nor accepts any liability for damages resulting from the handling or use of magnets. With your purchase, the buyer confirms that you have read and understand the following warnings: the buyer agrees that he/she is responsible for all damages/injuries caused by the magnets, which includes personal injuries, property damages or magnet damages. The buyer must agree with the terms before purchase. Pull forces we have provided are estimates only, we are not responsible for any inaccuracy of the magnet pull force. *Please test the pull force before any usage.* Magnets are very strong. Handling them with care is necessary to prevent personal injuries, property damages and magnet damages.  
CAN BE HARMFUL TO PACEMAKER WEARERS and others with MEDICAL IMPLANTS.

**INDOOR USE RECOMMENDED**  
OPERATING TEMPERATURE; -40° - 176° F (-40° - 80°C)

CONFIDENTIAL: USE OF THIS DRAWING WITHOUT WRITTEN AUTHORIZATION BY MAG-DADDY, LLC IS PROHIBITED		INCH <input checked="" type="checkbox"/> MM	SCALE: 2:1	Sheet Size: <b>A</b>
GENERAL TOLERANCE: UNLESS OTHERWISE SPECIFIED: ± .020 (.51mm)	THIRD ANGLE PROJECTION 	 295 Jamie Ln. Wauconda, IL 60084 www.magdaddyusa.com PH:(847) 719-5600		
ANGLES: ± 5°	APV.	Rev: 01	DWN. SS	DATE: 09/01/2023
MATERIAL: <b>SEE BOM</b>	PART DESCRIPTION: <b>1/2" MAGNETIC CABLE HOLDER 10 LBS. WHITE</b>	PART NO. <b>62401</b>		