

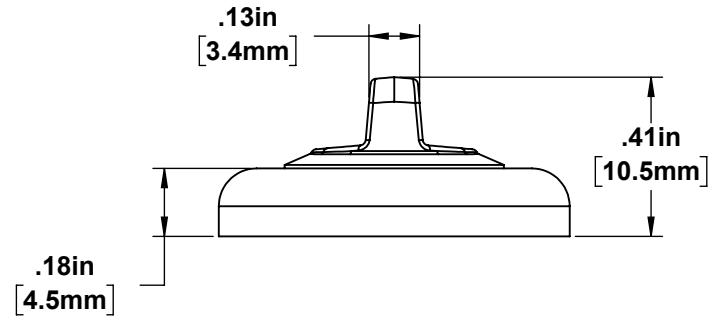

62416

| ITEM NO. | PART NUMBER | DESCRIPTION | MATERIAL | FINISH | QTY. |
|----------|-------------|--|--------------------------------------|-------------------------------|------|
| 1 | 62435 | CABLE TIE MOUNT .11"(2.8mm) X .23"(5.9mm) SLOT | POM-WHITE (NATURAL) POLYOXYMETHYLENE | | 1 |
| 2 | 82004W | 15LB., N39M, Ø.9" (23.2mm) MAGNET MOUNT Ø.256" (6.5mm) HOLE, WHITE | CUP-CRS DC01 MAGNET-NdFeB 39M | CUP-WHITE EPOXY MAGNET-NiCuNi | 1 |

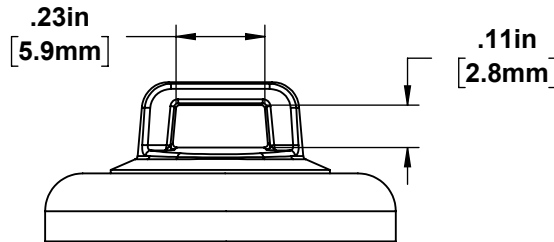
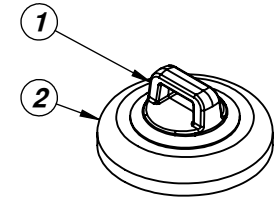
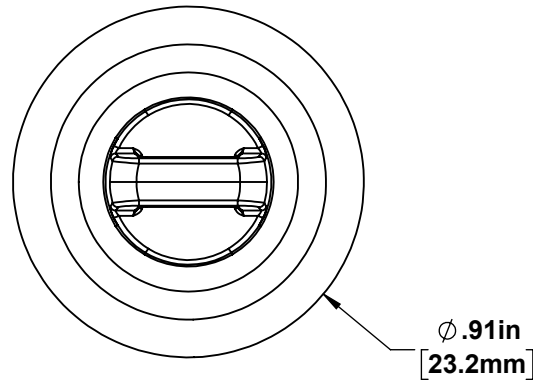

| | | |
|---|--|--|
|  UL LISTING Large Magnetic Cable Tie Mount | | |
| ANSI/UL 62275 | Positioning Devices TYPE 21 E359769 | Mechanical Tensile Strength: 15 LBS. (67N) |
| CAN | CSA-C22.2 No. 62275 | |
| ALL TESTING PERFORMED USING 3mm MIN. THICK 1008-1010 STEEL PLATE | | |

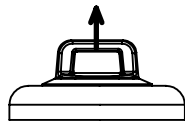



**TENSILE PULL
DIRECTION**

PLENUM RATED AH-2
Suitable in air handling systems

Please read before use! Disclaimer: Mag Daddy neither assumes nor accepts any liability for damages resulting from the handling or use of magnets. With your purchase, the buyer confirms that you have read and understand the following warnings: the buyer agrees that he/she is responsible for all damages/injuries caused by the magnets, which includes personal injuries, property damages or magnet damages. The buyer must agree with the terms before purchase. Pull forces we have provided are estimates only, we are not responsible for any inaccuracy of the magnet pull force. *Please test the pull force before any usage.* Magnets are very strong. Handling them with care is necessary to prevent personal injuries, property damages and magnet damages.
 CAN BE HARMFUL TO PACEMAKER WEARERS and others with MEDICAL IMPLANTS.

INDOOR USE RECOMMENDED
 OPERATING TEMPERATURE; -40° - 176° F (-40° - 80°C)

| | | | |
|---|--|--|--|
| CONFIDENTIAL: USE OF THIS DRAWING WITHOUT WRITTEN AUTHORIZATION BY MAG-DADDY, LLC IS PROHIBITED | | INCH <input checked="" type="checkbox"/> SCALE: 2:1 MM <input type="checkbox"/> | Sheet Size: A |
| GENERAL TOLERANCE: UNLESS OTHERWISE SPECIFIED: ± .020 (.51mm) ANGLES: ± 5° | THIRD ANGLE  PROJECTION |  295 Jamie Ln. Wauconda, IL 60084 www.magdaddyusa.com PH:(647) 719-5600 | |
| MATERIAL: SEE BOM | PART DESCRIPTION: LARGE MAGNETIC CABLE TIE MOUNT WHITE, 15 LBS. | APV. | Rev: 01 DWN. SS DATE: 05/30/2023 |
| | | PART NO. 62416 | |