

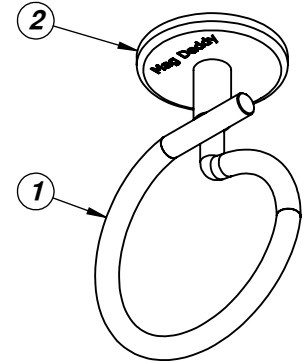

BRM4T200

ITEM NO.	PART NUMBER	DESCRIPTION	MATERIAL	Finish	QTY.
1	BR4T200	2" BRIDLE RING 1/4-20 THREADS	Mild Carbon Steel	ZINC	1
2	MAG4TF	1/4-20 FEMALE THREAD, 45M NEODYMIUM MAGNET MOUNT, 90lbs. Ø1.57" (40mm)	CUP-CRS DC01 Steel MAGNET-NdFeB 45M	CUP-NiCuNi MAGNET-NiCuNi	1

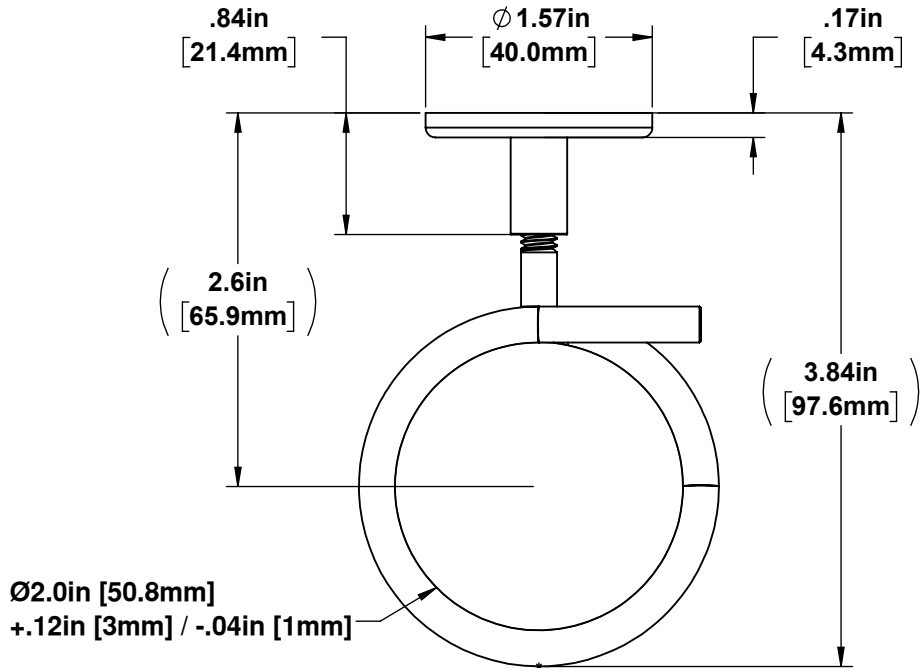
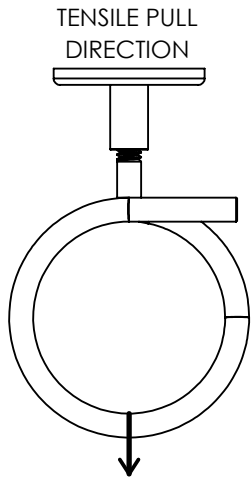

 UL LISTING Magnetic Bridle Ring 2" BRM4T200		
ANSI/UL 1565	Positioning Devices E359769	Mechanical Tensile Strength: 60 LBS. (265N)
CAN	CSA-C22.2 No. 18.5	
ALL TESTING PERFORMED USING 3mm MIN. THICK 1008-1010 STEEL PLATE		



PLENUM RATED AH-1

Suitable in air handling systems

Please read before use! Disclaimer: Mag Daddy neither assumes nor accepts any liability for damages resulting from the handling or use of magnets. With your purchase, the buyer confirms that you have read and understand the following warnings: the buyer agrees that he/she is responsible for all damages/injuries caused by the magnets, which includes personal injuries, property damages or magnet damages. The buyer must agree with the terms before purchase. Pull forces we have provided are estimates only, we are not responsible for any inaccuracy of the magnet pull force. *Please test the pull force before any usage.* Magnets are very strong. Handling them with care is necessary to prevent personal injuries, property damages and magnet damages. CAN BE HARMFUL TO PACEMAKER WEARERS and others with MEDICAL IMPLANTS.

INDOOR USE RECOMMENDED

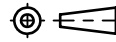
OPERATING TEMPERATURE; -40° - 176° F (-40° - 80°C)

<small>CONFIDENTIAL: USE OF THIS DRAWING WITHOUT WRITTEN AUTHORIZATION BY MAG-DADDY, LLC IS PROHIBITED.</small>		INCH <input checked="" type="checkbox"/> SCALE: 3:4 Sheet Size: A
GENERAL TOLERANCE: UNLESS OTHERWISE SPECIFIED: ± .020 (.51mm) ANGLES: ± 5°	THIRD ANGLE  PROJECTION	 295 Jamie Ln. Wauconda, IL 60084 www.magdaddyusa.com PH:(847) 719-5600
MATERIAL: SEE BOM	PART DESCRIPTION: 2" Magnetic Bridle Ring W/ 1/4"-20 Threads, 60LBS.	PART NO. BRM4T200
APV.	Rev: 02	DWN. SS DATE: 01/29/2024