

MDR300

ITEM NO.	PART NUMBER	DESCRIPTION	Material	Finish	QTY.
1	DR300	3" Cable D-Ring	Aluminum	Plain	1
2	82001	20LB Ø.9" (23.2mm) MAGNET MOUNT Ø.197" (5mm) HOLE, SILVER	CUP-1008-1010 Steel MAGNET-NdFeB 45M	CUP-ZINC MAGNET-NiCuNi	2
3	72684	#10-32 x 3/4" Phillips Drive Flat Head Machine Screw	18-8 Stainless Steel	Plain	2
4	70858	#10-32 Nylon Insert Lock Nut	18-8 Stainless Steel Nut, Nylon Insert	Plain	2

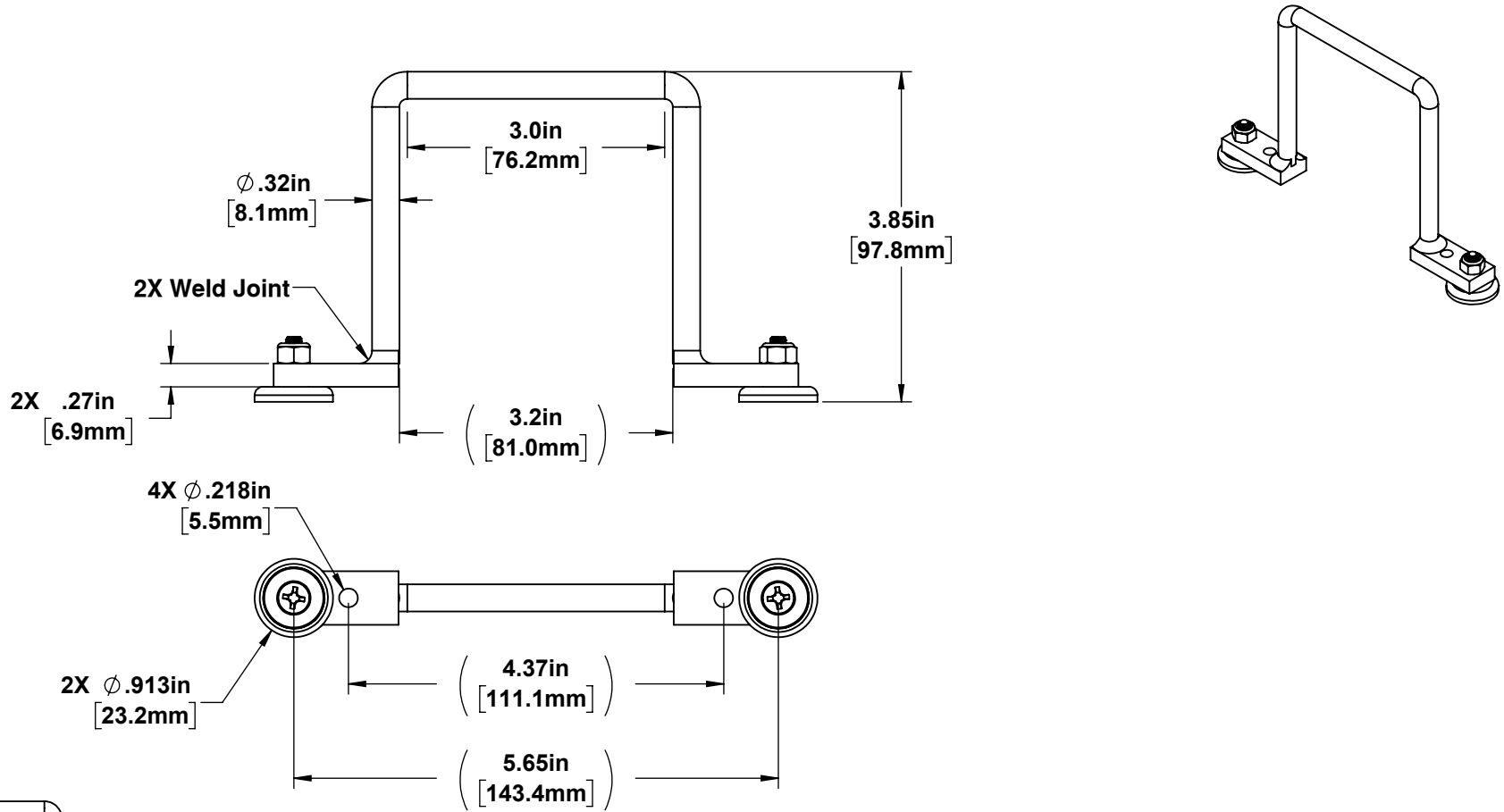

MECHANICAL TENSILE STRENGTH: 20 LBS. (89N)
ALL TESTING PERFORMED USING
3mm MIN. THICK 1008-1010 STEEL PLATE

INDOOR USE RECOMMENDED
OPERATING TEMPERATURE; -40° - 176° F (-40° - 80°C)
SUITABLE FOR USE IN AIR HANDLING SYSTEMS

<small>CONFIDENTIAL: USE OF THIS DRAWING WITHOUT WRITTEN AUTHORIZATION BY MAG-DADDY, LLC IS PROHIBITED</small>		INCH <input checked="" type="checkbox"/> MM <input type="checkbox"/>	SCALE: 1:2	Sheet Size: A
GENERAL TOLERANCE: UNLESS OTHERWISE SPECIFIED: ± .020 (.51mm)		THIRD ANGLE PROJECTION	 295 Jamie Ln. Wauconda, IL 60084 www.magdaddyusa.com PH:(847) 719-5600	
ANGLES: ± 5°		APV. <input type="checkbox"/> DWN. <input checked="" type="checkbox"/> SS	Rev: 00	DATE: 02/03/25
MATERIAL: SEE BOM	PART DESCRIPTION: 3" Magnetic Cable D-Ring 20 LBS. (89N)	PART NO. MDR300		