

PCBM100		ITEM NO.	PART NUMBER	DESCRIPTION	Material	QTY.
1	82000	10LB N35M Ø3/4" (19mm) MAGNET MOUNT Ø.193"(4.9mm) HOLE, SILVER	CUP-STEEL MAGNET-35M NEODYMIUM	1		
2	Heyco 10620F	PCB Support - Screw and Lock HHCBS-12 (.75") V-0 Natural	Nylon 6/6	1		
3	Fastenal_11260110	6-32 X 3/8" Phillips Flat Head Screw Thread Cutting, 100° Countersink	18-8 Stainless Steel	1		

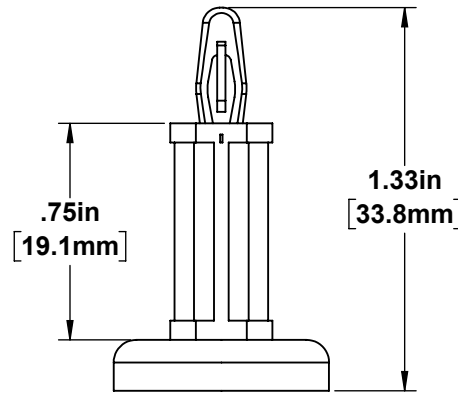

Mechanical Tensile Strength:	10 LBS. (44N)
ALL TESTING PERFORMED USING 3mm MIN. THICK 1008-1010 STEEL PLATE	

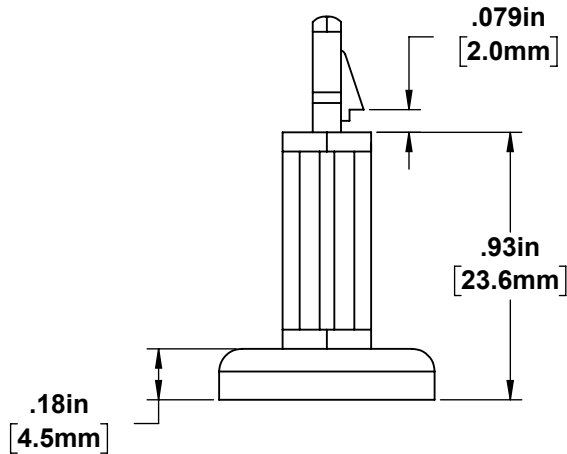
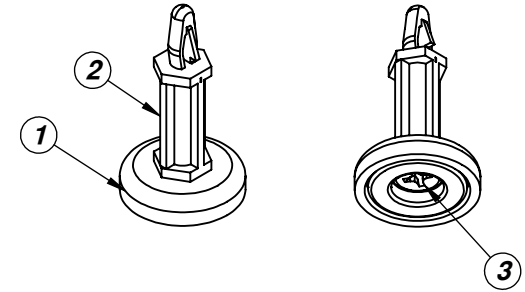
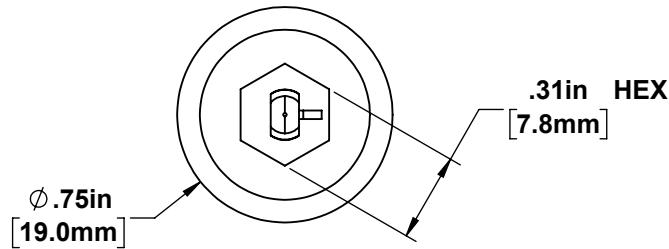

Please read before use! Disclaimer: Mag Daddy neither assumes nor accepts any liability for damages resulting from the handling or use of magnets. With your purchase, the buyer confirms that you have read and understand the following warnings: the buyer agrees that he/she is responsible for all damages/injuries caused by the magnets, which includes personal injuries, property damages or magnet damages. The buyer must agree with the terms before purchase. Pull forces we have provided are estimates only, we are not responsible for any inaccuracy of the magnet pull force. *Please test the pull force before any usage.* Magnets are very strong. Handling them with care is necessary to prevent personal injuries, property damages and magnet damages.
CAN BE HARMFUL TO PACEMAKER WEARERS and others with MEDICAL IMPLANTS.

INDOOR USE RECOMMENDED

OPERATING TEMPERATURE; -40° - 176° F (-40° - 80°C)

CONFIDENTIAL: USE OF THIS DRAWING WITHOUT WRITTEN AUTHORIZATION BY MAG-DADDY, LLC IS PROHIBITED		INCH <input checked="" type="checkbox"/> MM	SCALE: 3:2	Sheet Size: A
GENERAL TOLERANCE: UNLESS OTHERWISE SPECIFIED: ± .020 (.51mm)	THIRD ANGLE PROJECTION	 295 Jamie Ln. Wauconda, IL 60084 www.magdaddyusa.com PH:(847) 719-5600		
ANGLES: ± 5°	APV.	Rev: 01	DWN. SS	DATE: 07/17/2023
MATERIAL: SEE BOM	PART DESCRIPTION: 10LB. MAGNETIC SCREW AND LOCK PCB MOUNT	PART NO. PCBM100		